

ACROSS

MOVE BETWEEN WORLDS



SUZUKI

MOVE BETWEEN WORLDS

Life today doesn't stay in one lane. It shifts from meetings to school runs, from coffee shops to conference calls, from airport lounges to weekend escapes. It's weekday responsibility and weekend freedom, often in the very same breath.

The all-new Suzuki Across moves with that rhythm. A sophisticated, intelligent SUV designed to adapt as your day unfolds, giving you the confidence to transition seamlessly and the freedom to live fully in every part of your world.



IMPRESS ON THE GO

Stand out with the new Across that features a progressive design with a bold, aesthetic stance. Its chiselled front, distinctive three-dimensional headlamps, and connected rear LED tail lamps create a bold and memorable road presence - complemented by sleek alloy wheels, wrap-around windows and aerodynamic contours.

The Across makes a great impression from every angle, in every detail.



10.25" digital display

The meter display comes with a multi-information colour display that shows real-time information about the vehicle behaviour and operation. The speedometer can be set in two different modes, classic and standard. The centre area displays the speed and DSBS II (Dual Sensor Break Support II)* details. On either side of the centre display, you can customise the screen to display a variety of information such as clock, media, turn-by-turn navigation and more, all controlled via the toggle switch mounted on the steering wheel.

*Available on GLX

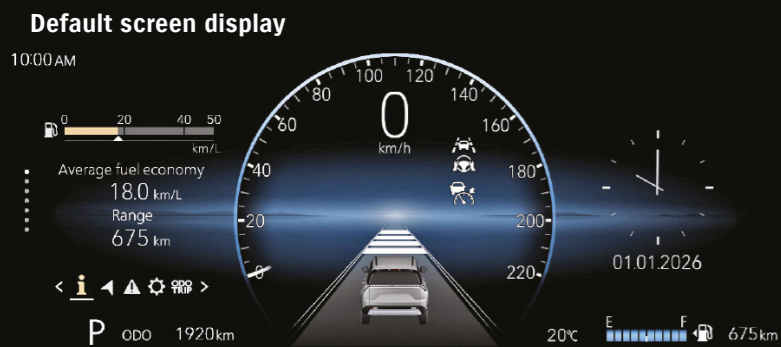

360°-view camera

The 360°-view camera system* features four cameras - at the front, rear, and both sides, which are connected to the centre display. The system allows for easy manoeuvrability through key functions including a 3D opening view for the driver to assess the surroundings, a top view for safer parking, and visual and audio alerts to warn of nearby objects.

*Available on GLX

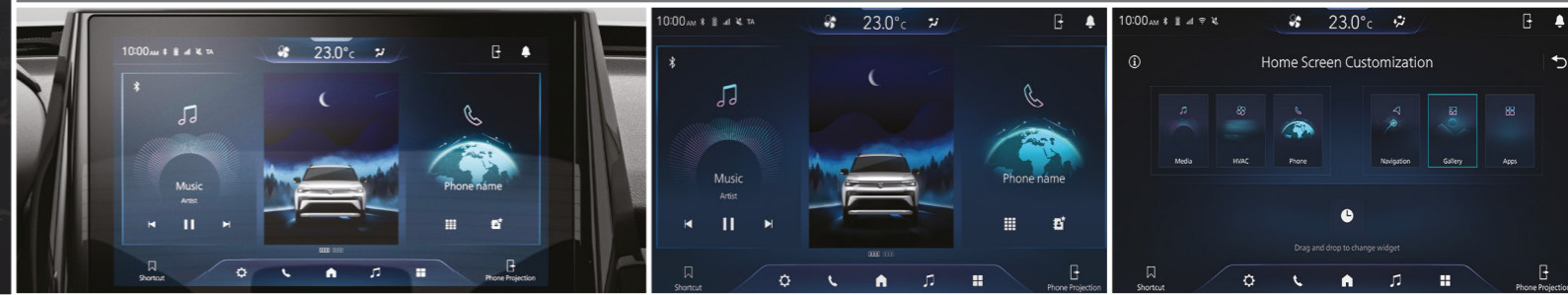

10.1" Touchscreen with audio display

The 10.1" HD capacitive touchscreen delivers a quick and accurate response, putting seamless control at your fingertips. It features smartphone connectivity with Apple CarPlay® and Android Auto™ via USB or Wi-Fi, along with Bluetooth® hands-free calling and music playback. The display also provides key vehicle status information, including a clear rear-view camera feed for added confidence when reversing. For a more personalised experience, the home screen can be customised to prioritise your most-used functions.

Apple CarPlay® lets drivers access the voice-activated Siri® personal assistant on their iPhone to get directions, make calls, play music and send and receive messages without taking their hands off the steering wheel.

Android Auto™ makes the time drivers spend on the road safer and more fun by letting them use hands-free help from Google Assistant to access a wide variety of supported apps on their Android™ smartphone.

Apple CarPlay®



Android Auto™



Apple CarPlay is supported in the countries listed at the following link: <https://www.apple.com/ios/feature-availability/#applecarplay-applecarplay>
 For more details, including iPhone models and iOS versions compatible with Apple CarPlay, see: <https://www.apple.com/ios/carplay/>
 Apple, Apple CarPlay, iPhone and Siri are trademarks of Apple Inc., registered in the U.S. and other countries.
 Wi-Fi is a registered trademark of Wi-Fi Alliance.
 Android Auto is supported in the countries listed at the following link: <https://www.android.com/autof>
 To use Android Auto on your car display, you'll need an Android phone running Android 8 or higher, an active data plan, and the Android Auto app.
 Wireless use of Android Auto requires a compatible Android 11.0+ phone and compatible active data plan. Check g.co/androidauto/requirements for compatibility.
 Some features and devices may not be available in all countries. Subject to availability.
 Google, Android, Android Auto, Google Maps and other marks are trademarks of Google LLC.
 Bluetooth is a registered trademark of Bluetooth SIG, Inc.

ACROSS

Head-up Display

The combiner type Head-Up Display* lets you read driving details by projecting an array of information such as speed, instant fuel economy and intersection navigation without taking your eyes off the road.

*Available on GLX



Infinity sound system*

Engineered for those who move seamlessly between worlds, the premium Infinity sound system transforms every journey into an immersive experience.

Eight strategically positioned speakers – including door speakers, a centre speaker, tweeters and a subwoofer – work in harmony, with sound finely tuned by a digital signal processor to suit every drive. The result is powerful, high-definition audio with remarkable clarity, depth and impact.

Whether you're navigating the city or escaping into the wild, every note, beat and lyric is brought to life with precision – creating a rich, concert-like soundscape that moves with you, wherever the road leads.

*Available on GLX

SPACE & CONVENIENCE HIGHLIGHTS

- Smart powered tailgate for hands-free access
- Flexible luggage space for busy days and big weekends
- Thoughtful storage throughout the cabin



ACROSS

Panoramic Sunroof

The panoramic sunroof* offers an exhilarating open-roof experience with two glass panels (one in front of the other) which can both be slid open to provide one of the biggest opening sunroofs in its class. Additionally, the sunroof is equipped with a sunshade that completely blocks light when closed.

*Available on GLX



Electric parking brake

The electric parking brake system* can be set or released via a fingertip switch. This eliminates concerns about insufficient engagement when parking and about driving off with the brakes partially engaged afterwards.

*AT model only

Set

Pulling the switch will engage parking brake (EPB). When AUTO mode is on, the parking brake can be engaged simply by positioning the drive shift to P.

*AUTO mode is off by default. To switch it on, pull and hold the EPB switch for at least 5 seconds while brake pedal is depressed.

Release

Pressing the switch while depressing the brake pedal will disengage parking brake. The parking brake can also be disengaged by depressing the accelerator pedal with the drive shift in D or R.

*Brake will not disengage if the driver's seatbelt is not buckled or the driver's door is open.



Eight-way power seat

The eight-way adjustable power seat* can be operated easily through switch knobs on the side of the seat cushion, enabling effortless adjustments to find the ideal position.

*Available on GLX

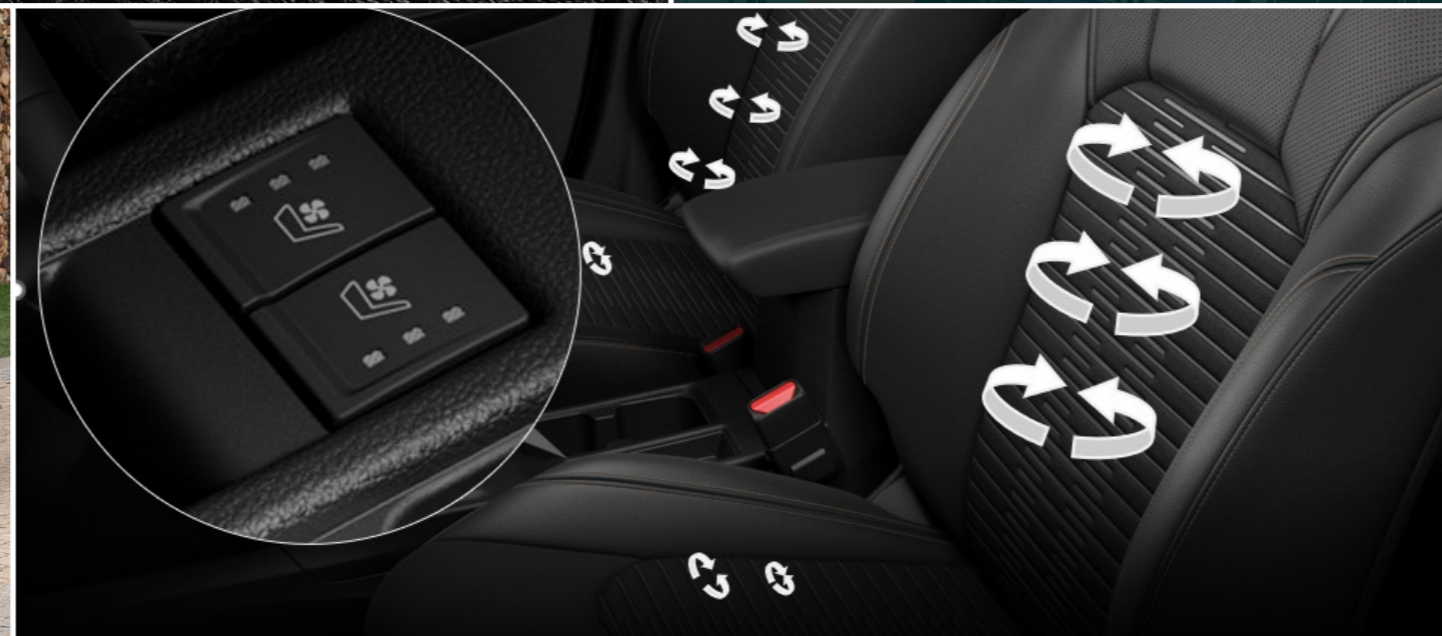

Ventilated seats

The ventilated front seats* provide immediate cooling to their occupants by drawing in cool air from the air conditioner. The added ventilation also removes cabin stuffiness.

*Available on GLX

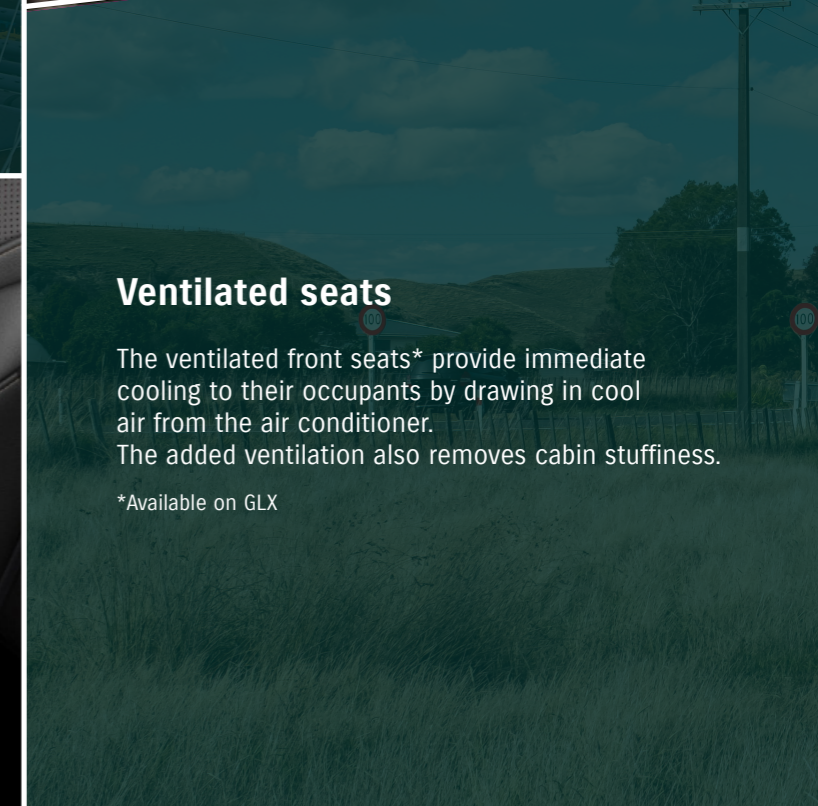

Automatic air conditioner with PM2.5 filter

Standard in all variants, the air conditioner features automatic temperature control which maintains the set cabin temperature. Along with cooling, the PM2.5 compatible air filters release clean air through vents placed at the front and the rear of the cabin.



Paddle shift

The paddle shift* enables gear changes without the need for a manual clutch, enhancing the driving experience. Enjoy greater control over the vehicle's performance and responsiveness by manually upshifting or downshifting gears.

*AT model only



BETWEEN CITY TRAFFIC AND THE OPEN ROAD

Get ready for an elevated driving experience. The powerful yet efficient performance delivers a smooth and confident ride, no matter where the road takes you.

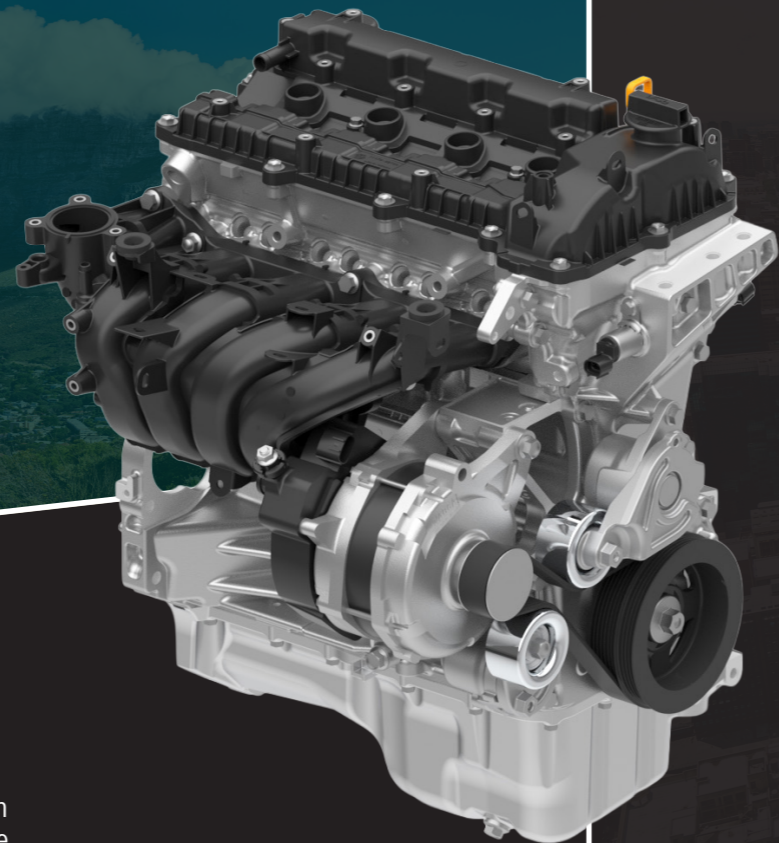

K15C DUALJET engine

The 1.5-litre engine delivers high efficiency, low emissions, strong output and torque. Excellent efficiency is achieved through various features. Dual fuel injectors are placed close to the intake valves and the compression ratio is raised for efficient fuel combustion, the combustion temperatures are lowered and pumping loss is reduced by the cooled exhaust gas recirculation (EGR) system, and adoption of roller rocker arms for valve lifters reduces frictional speed.

SHVS mild-hybrid system

The 12V SHVS mild-hybrid system incorporates an integrated starter generator (ISG), which performs as a generator as well as an electric motor, and a lithium-ion battery. In situations such as when starting from a standstill or accelerating, the system helps suppress fuel consumption by providing electric motor assist using electricity generated through regenerative braking.

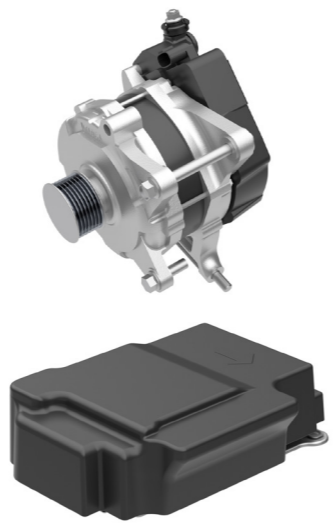

Transmission

The new Across has a choice of 5-speed manual transmission and 6-speed automatic transmission. Both are optimised for the best balance of performance and fuel efficiency. A straight type of shift pattern is adopted for the automatic transmission for simple and easy operation while the manual transmission features light, smooth and precise gear shifting with the convergent locating system.

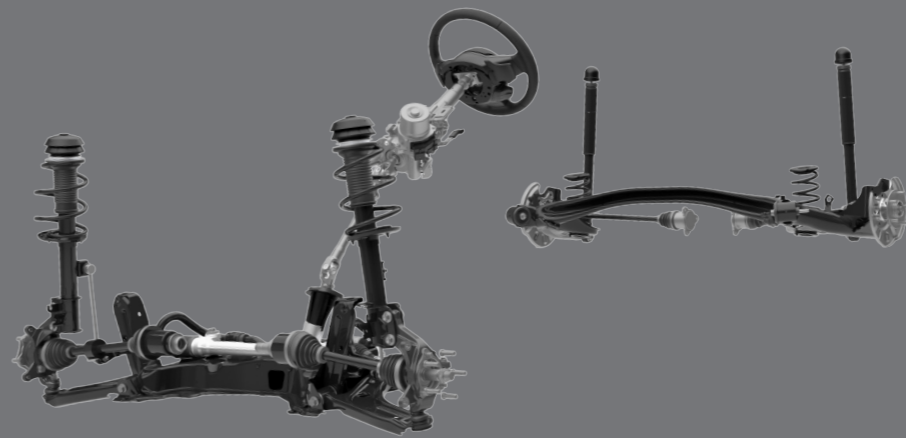

Suspension and steering

Suspensions are finely tuned for sporty handling and superb ride quality, delivering precise and responsive control.

The steering calibration ensures a lighter feel for effortless city manoeuvring, while providing proper effort buildup for confident handling at highway cruising speeds.

Hill-hold control

The hill-hold control function makes hill start easier by preventing the car from rolling backward for up to two seconds when the driver moves his or her foot from the brake pedal to the accelerator pedal.



SAFETY MEETS INNOVATION

Suzuki Safety Support, a host of advanced features and smart technology work together to make everyday driving safer.

*There is a limit to the ability of cameras and sensors to detect obstacles, lanes and traffic signs. Please do not rely on this system alone. Always drive safely. Vehicle-to-vehicle distance varies depending on vehicle speed.

Dual Sensor Brake Support II (DSBS II)

Millimetre-wave radar and a monocular camera are employed to detect vehicles, motorcycles, bicycles* and pedestrians directly or diagonally ahead of the vehicle. If a collision seems possible, audio and visual warnings are issued to alert the driver. If the driver brakes with insufficient force, brake assist automatically engages to help slow the vehicle. And if the probability of a collision increases, the system automatically applies brake force to help reduce impact force and mitigate damage.

*Available on GLX.

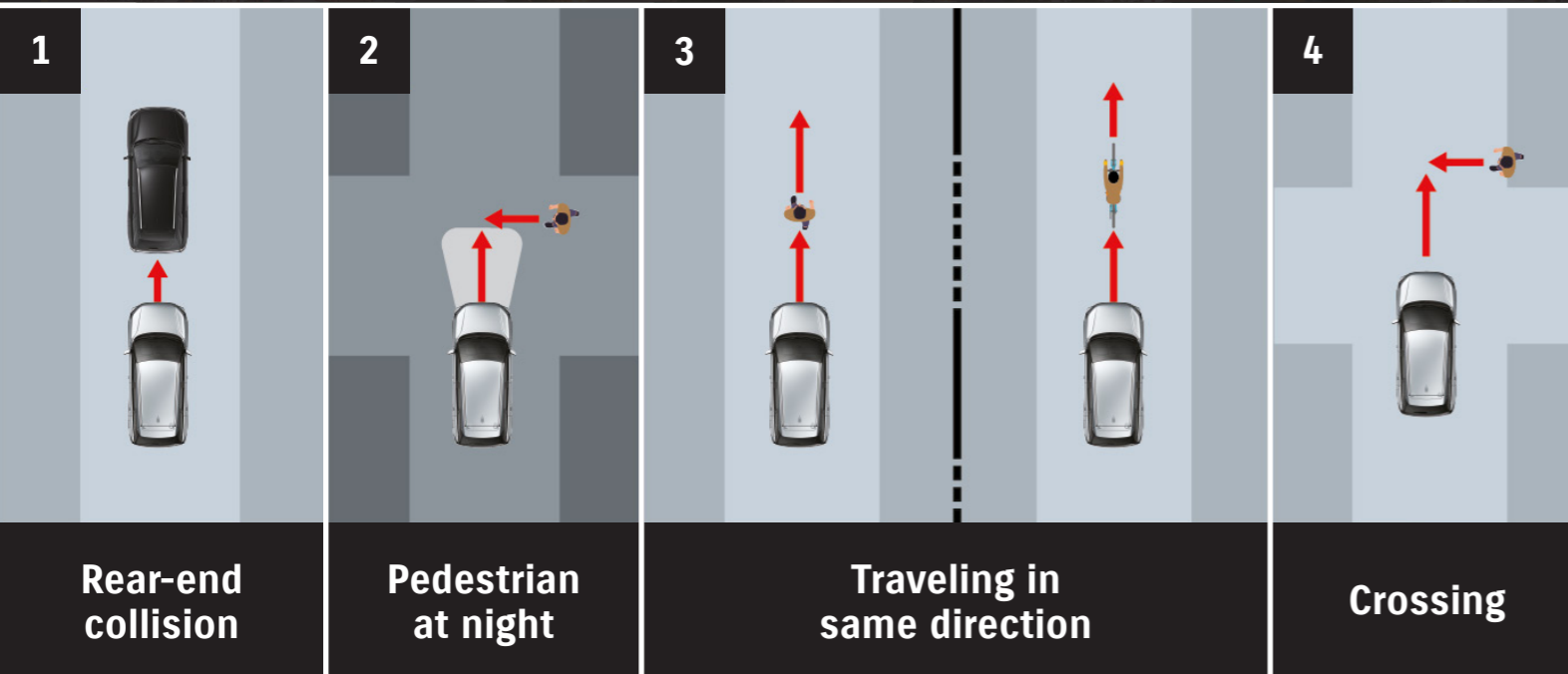

Adaptive Cruise Control (ACC)

Adaptive cruise control helps reduce driver fatigue on long trips and when driving on highways. When the ACC switch is engaged, the system uses a millimetre-wave radar and monocular camera to detect the presence and distance of vehicles ahead, and accelerates or decelerates as needed to maintain a set distance from the vehicles. If the road ahead is clear, it will maintain the speed at which the vehicle was travelling when the switch was engaged.

*Available on GLX.

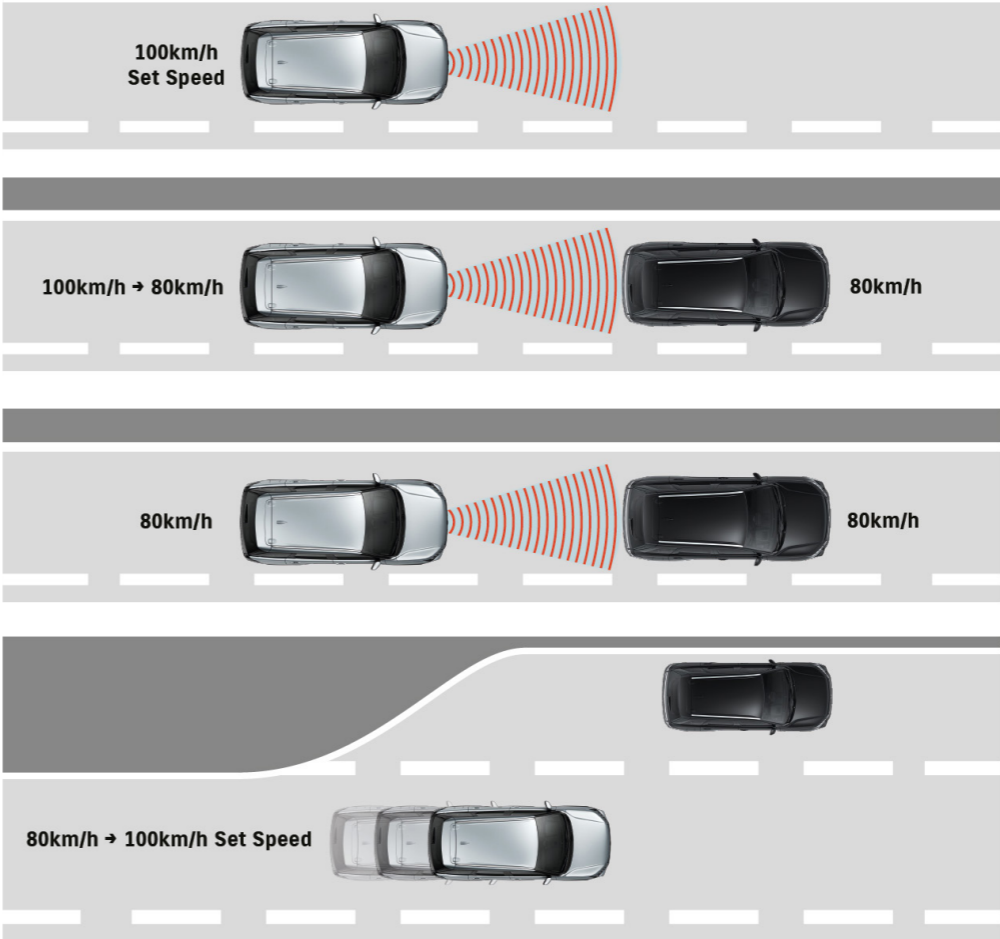

1. Constant speed control

If there are no vehicles ahead, the speed set by the driver is maintained.

2. Deceleration control

Speed is reduced to match the speed of the vehicle ahead.

3. Following speed control

Speed is maintained to match the speed of the vehicle ahead.

4. Acceleration control

If the vehicle in front departs from the lane and there is sufficient distance from any additional vehicle ahead, the Across automatically reaccelerates to the set speed.

Lane Keep Assist (LKA)

When adaptive cruise control is activated, LKA helps the driver maintain the vehicle's position in the centre of the lane. In addition, if it senses that an adjacent vehicle or structure such as a temporary roadwork barrier or other obstacle is too close to the driver's vehicle, it provides steering assistance to help maintain a safe distance.

*Available on GLX.

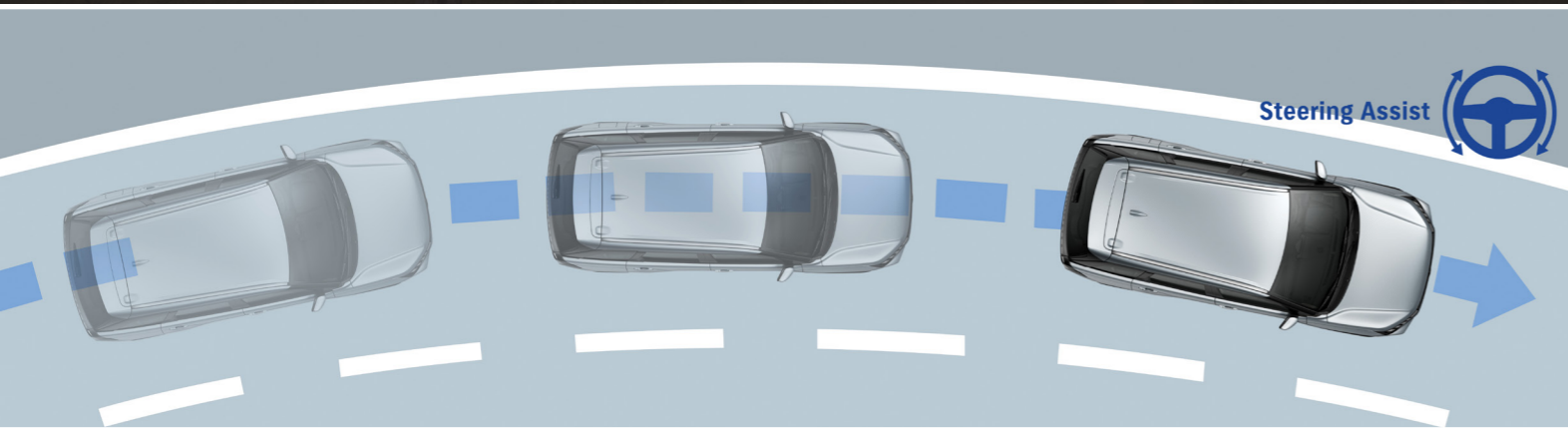

Lane Departure Prevention (LDP)

When driving, LDP detects the left and right lane demarcation lines and predicts the vehicle's path. If the system determines that there is a high possibility of the vehicle deviating from the lane due to driver distraction, the system alerts the driver by vibrating the steering wheel or sounding an audio alert. It provides steering assistance to help the driver return to the centre of the lane.

*Available on GLX.

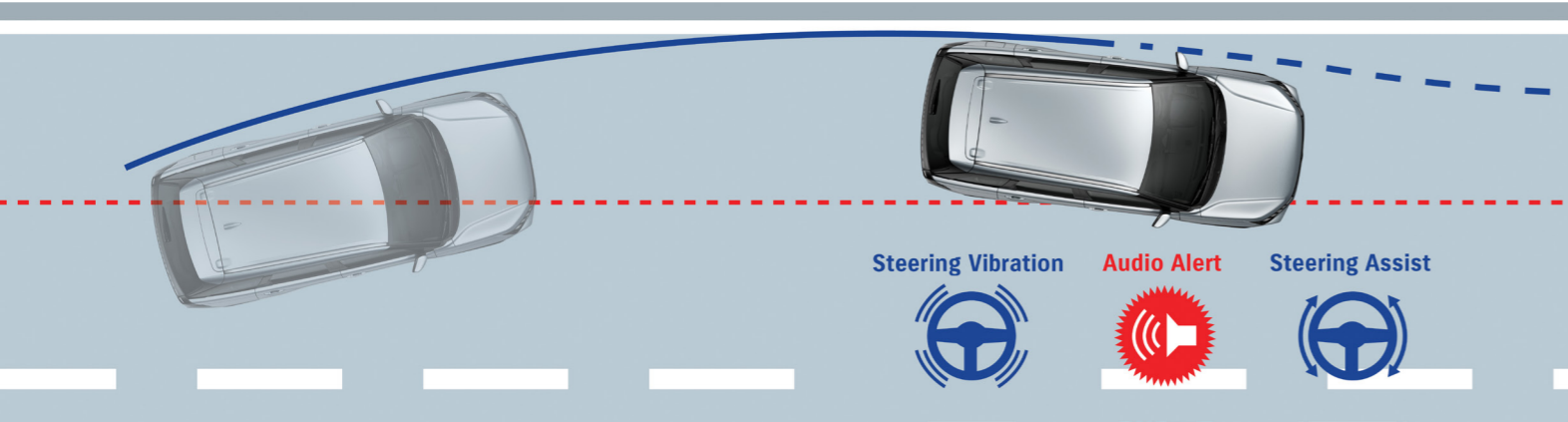

Blind Spot Monitor (BSM)

The blind spot monitor uses millimetre-wave radar sensors in the rear bumper to detect vehicles located in or approaching the rear blind spots on either side of the vehicle. When a vehicle is detected, a warning icon appears in the door mirror on the side that the vehicle is approaching. If the driver activates the turn signal on that side, the icon flashes an audio warning sound.

*Available on GLX.

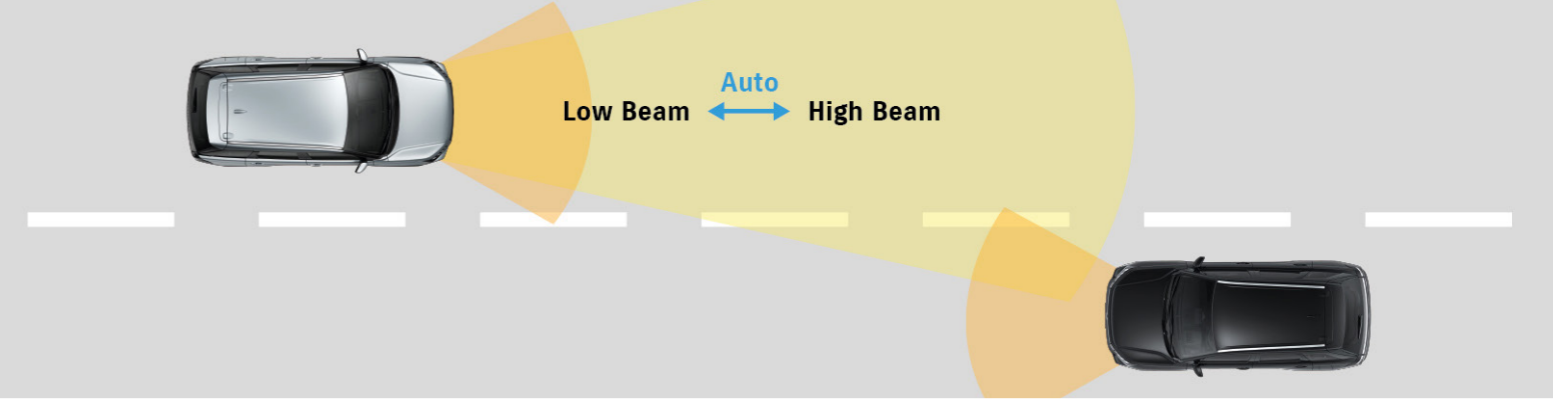
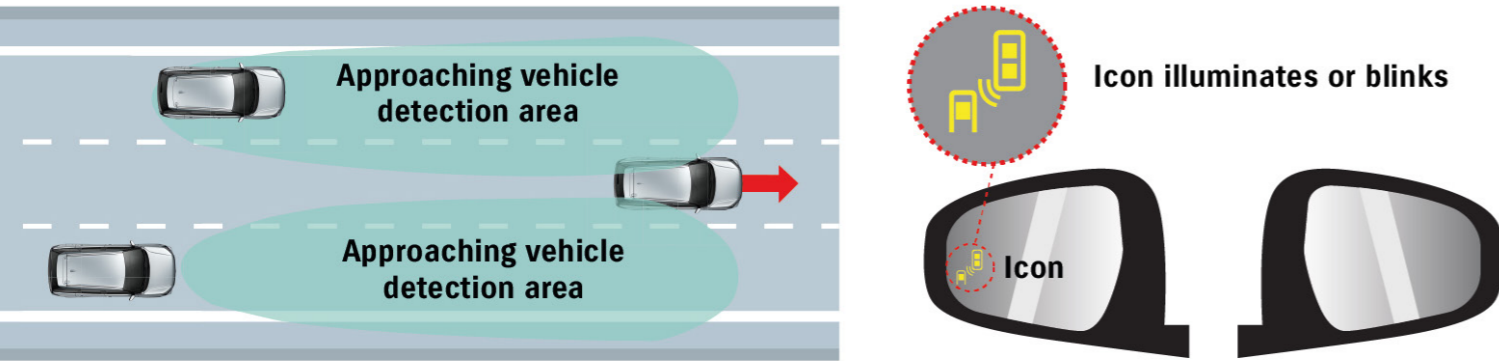

High beam assist

When driving with the high beams on, the headlamps automatically switch to low beam when you experience oncoming traffic or vehicles driving ahead, or if you are travelling in a well-lit area. The headlamps automatically return to the high beams when the road ahead is clear and the surrounding area is poorly lit. High beam assist is active only at speeds above 30km/h when the light switch is set to Auto.

*Available on GLX.

Rear Cross Traffic Alert (RCTA)

RCTA is a supplementary safety feature that uses blind spot monitors to detect and warn of vehicles approaching from the left or right when backing out of a parking space or other location.

*Available on GLX.

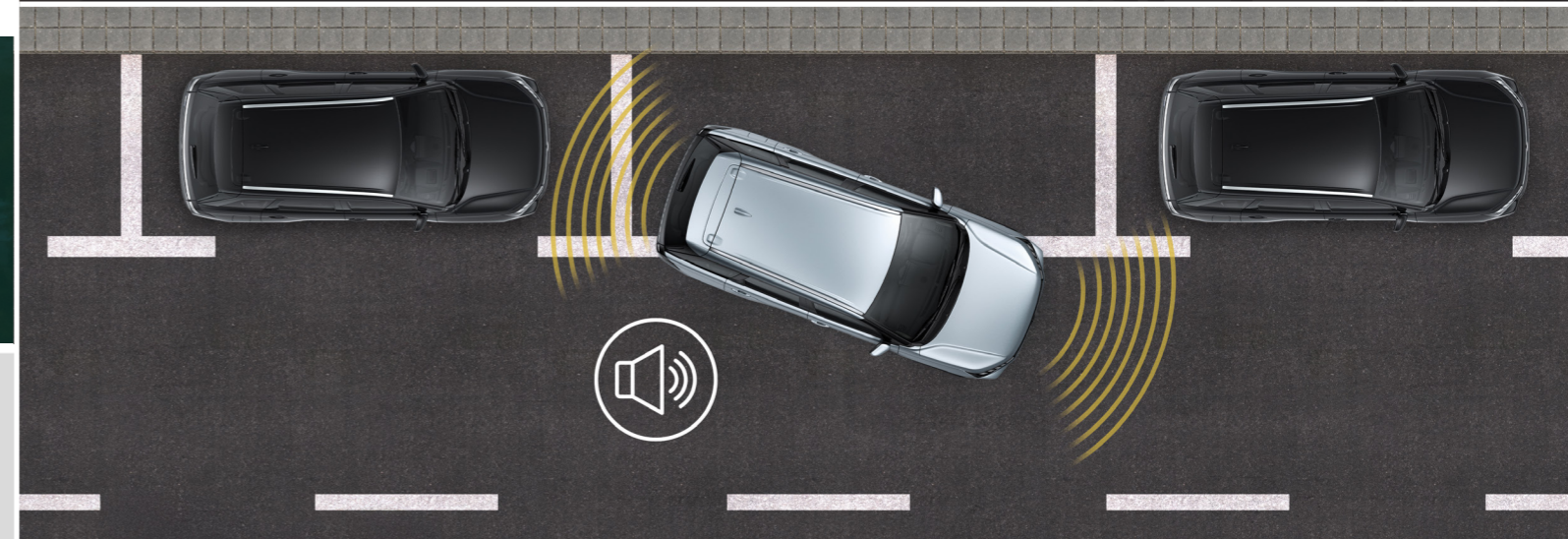

Front and Rear Parking Sensor

In the GLX grade, ultrasonic sensors in the front and rear bumper detect obstacles and warning beep sounds indicate the obstacle's proximity. In GL grade, only rear parking sensors are present.

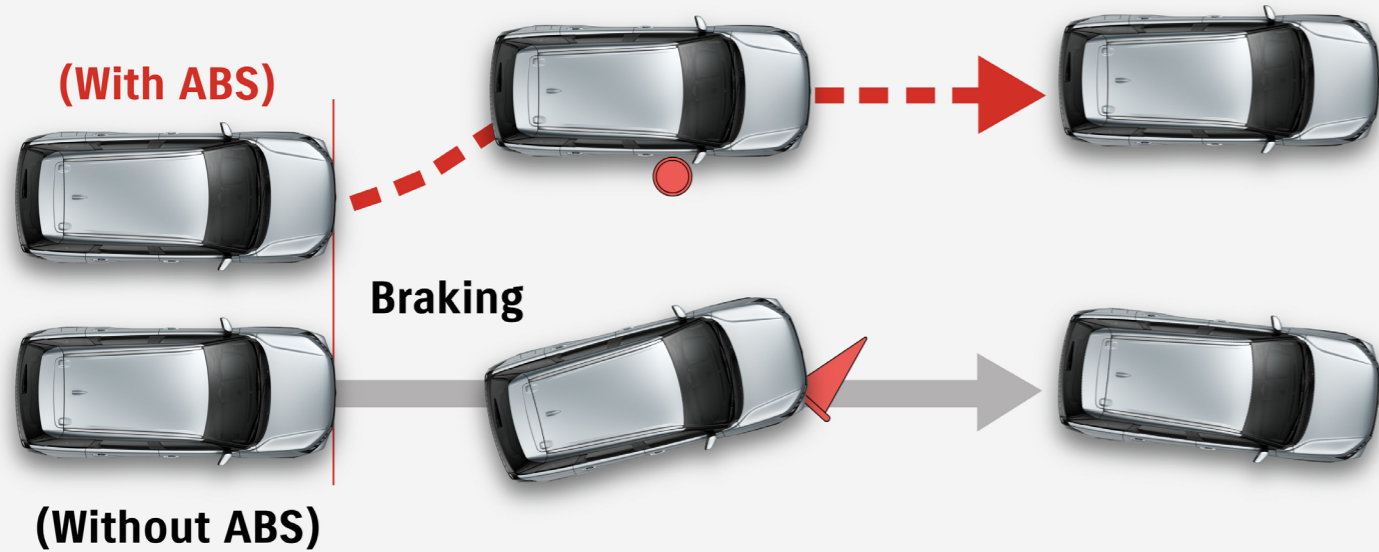

ABS with EBD

In an emergency braking situation, the Anti-lock Brake System* (ABS) keeps tyres from locking up and supports the driver to maintain steering ability. In addition, Electric Brake Force Distribution (EBD) shortens the braking distance by optimally distributing force to the front and rear wheels if there is a large load, such as when the car is full of passengers.

*ABS and EBD are assistive technologies; it does not reduce the need to practice safe, careful driving.

Pedestrian Injury Mitigating Body

The structures of the vehicle's bonnet, front windscreen wiper area, front bumper and other parts absorb impact with the aim of mitigating head and leg injuries in the event of a collision with a pedestrian.

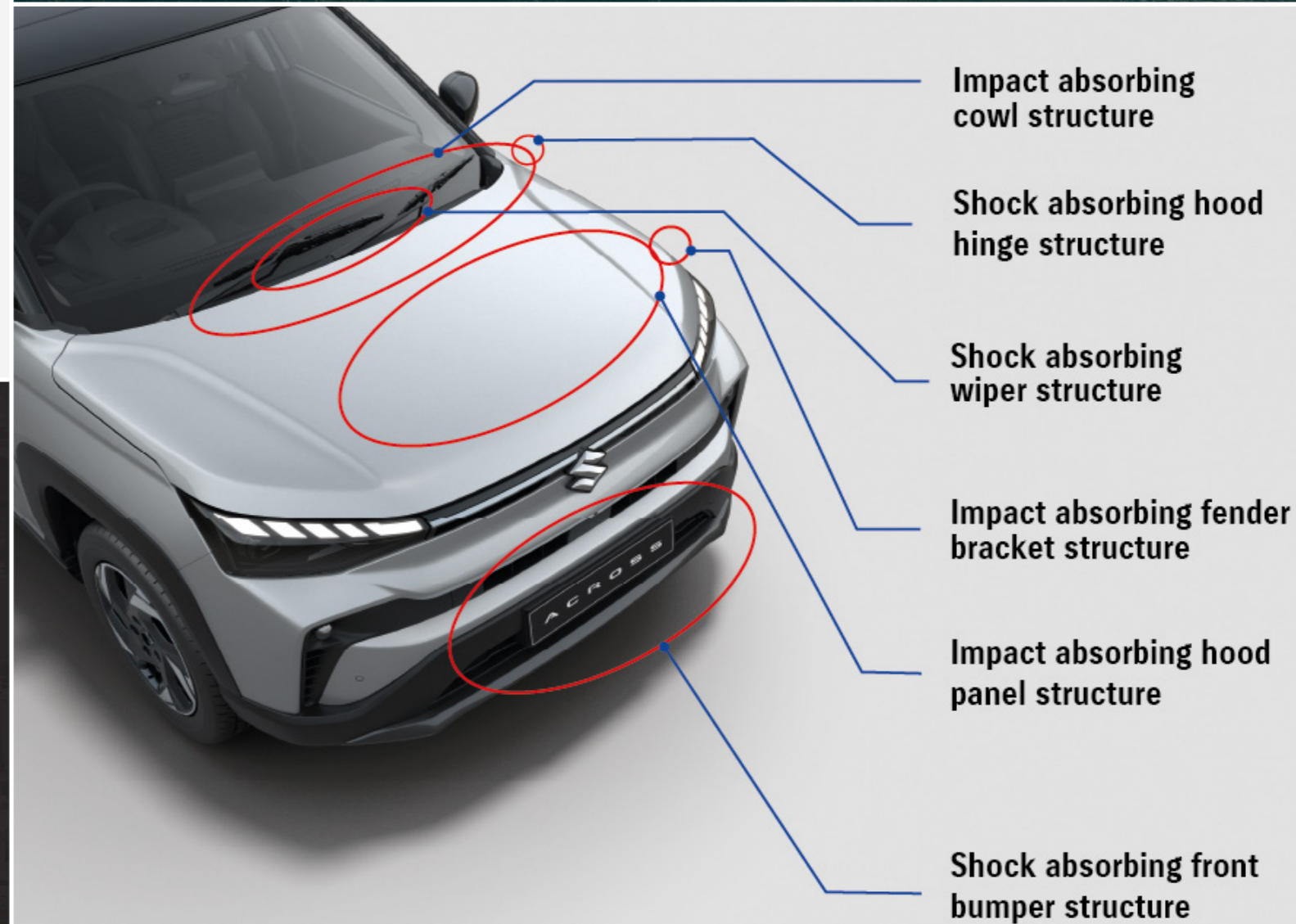

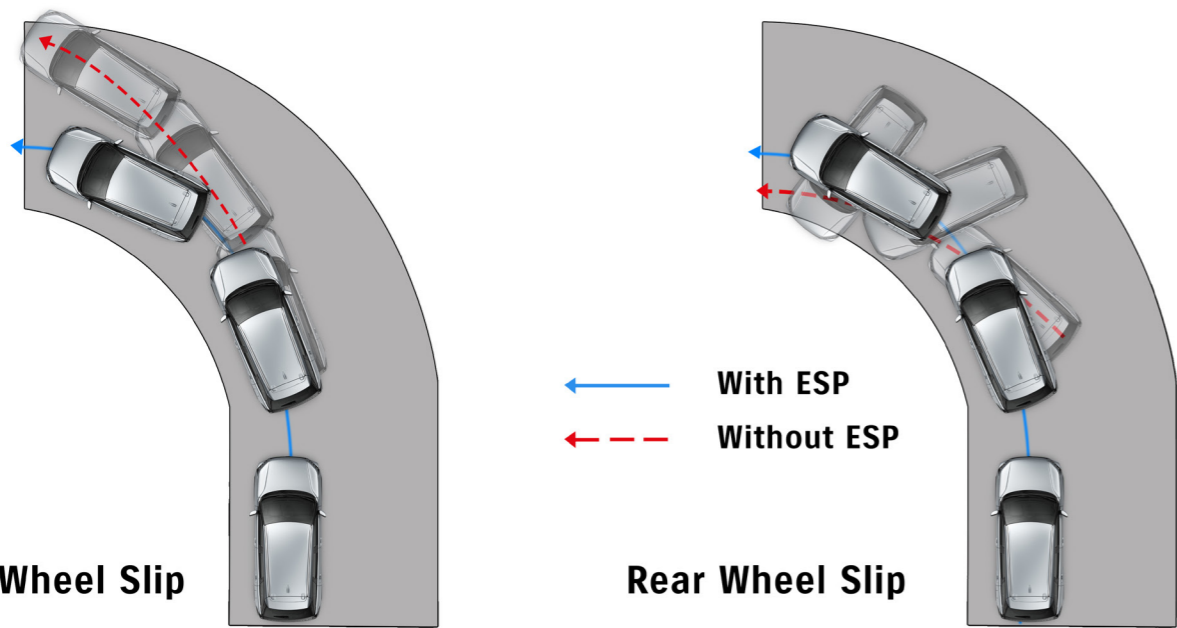

Front Wheel Slip

Rear Wheel Slip

ESP

ESP*** technology helps drivers control the vehicle during cornering, and assists them in maintaining traction when accelerating on loose or slippery road surfaces. If wheel slip is detected, the ESP system automatically regulates engine torque and selectively applies the brakes to help drivers maintain control.

***ESP is a registered trademark of Mercedes-Benz Group AG.



Six Airbags

Airbags protect both the driver and passengers. The SUV comes with standard SRS airbags. Front SRS side airbags reduce impact to the chest in case of side collision and SRS curtain airbags reduce impact to the head in all grades.



MAJOR SPECIFICATIONS

Number of doors	5 doors
Engine	Petrol, 1.5ℓ
Drive system	2WD

DIMENSIONS

Overall length (mm)	4 360	
Overall width (mm)	1 795	
Overall height (mm)	1 655	
Wheelbase (mm)	2 600	
Tread	Front (mm)	1 530
	Rear (mm)	1 535
Minimum turning radius (m)	5,4	
Minimum ground clearance (mm)	210	

CAPACITIES

Seating capacity	persons	5
Fuel tank capacity	litres	45

ENGINE

Type	K15C
Number of cylinders	4
Number of valves	16
Piston displacement (cm ³)	1 462
Bore x stroke (mm)	74 x 85
Compression ratio	12,0
Maximum output (kW)	75.8/6,000
Maximum torque (Nm)	136.8/4,400
Fuel distribution	Multi-point injection

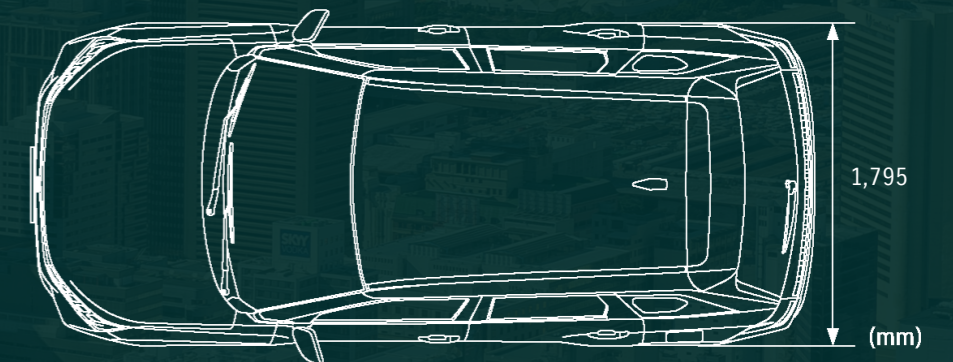
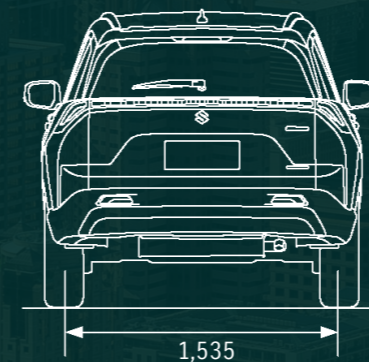
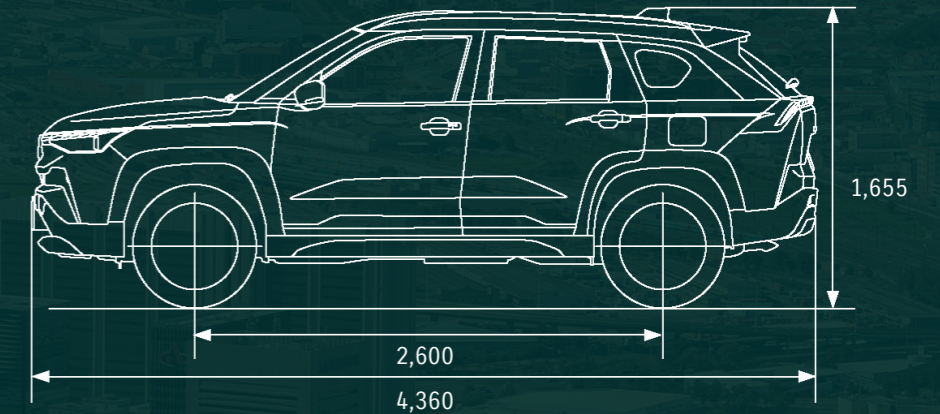
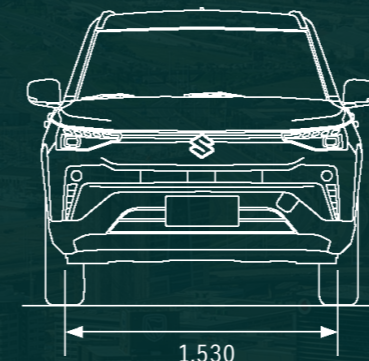

TRANSMISSION

Type		5MT	6AT
Gear ratio	1 st	3,909	4,667
	2 nd	2,043	2,533
	3 rd	1,407	1,556
	4 th	1,065	1,135
	5 th	0,816	0,859
	6 th	-	0,686
	Reverse	3,250	3,394
Final gear ratio		4,688	3,683

CHASSIS

Steering		Rack and Pinion
Brakes	Front	Ventilated disc
	Rear	Solid disc
Suspension	Front	MacPherson strut
	Rear	Torsion beam
Tyres		215/60R17

WEIGHTS

Kerb weight (min. / with full option) (kg)	1,175-1,220	1,200-1,250
Gross vehicle weight (kg)	1,635-1,680	1,660-1,710

MAJOR EQUIPMENT

Transmission	5MT/6AT	6AT
Grade	GL	GLX

CHASSIS

Tyres and wheels	215/60 R17 + alloy wheels (Painted)	⊗	-
	215/60 R17 + alloy wheels (Machined)	-	⊗
Spare tyre		⊗	⊗

EXTERIOR

Sunroof		-	⊗
Front grille	Satin Chrome	⊗	⊗
	Silver	⊗	-
Roof rails	Grey	-	⊗
Outside door handles	Body coloured	⊗	⊗
Outside mirrors	Electric fold	⊗	⊗
Skid plate garnish	Front	⊗	⊗
	Rear	⊗	⊗
Door beltline garnish	Material	⊗	⊗
Electromagnetic		⊗	⊗
Power back door with smart handsfree function		⊗	⊗

VISIBILITY

Headlamps	LED projector	⊗	⊗
Automatic lamps		⊗	⊗
Position lamps	LED	⊗	⊗
Fog lamps	Front	⊗	⊗
	Rear	-	-
Front door	Green glass + UV CUT	⊗	⊗
Rear door, rear quarter, tailgate window	Green glass	⊗	-
	Dark gray glass	-	⊗
Front wiper	Variable Intermittent	⊗	⊗
Rear wiper	Fixed Intermittent	⊗	⊗
Electric demister		⊗	⊗
Day/night rearview mirror	Automatic dimming	⊗	⊗

Transmission	5MT/6AT	6AT
Grade	GL	GLX

STEERING AND INSTRUMENT PANEL

3-spoke steering wheel	Leather covered	-	⊕
	Tilt-adjustable steering wheel	⊕	⊕
	Telescopic-adjustable steering wheel	⊕	⊕
	With audio controls	⊕	⊕
	With cruise control	⊕	⊕
	With hands-free phone control	⊕	⊕
	Paddle shift	⊕ (AT)	⊕ (AT)
Electronic power steering		⊕	⊕
Tachometer	Digital	⊕	⊕
Information display	10.25-inch colour TFT display	⊕	⊕
	Clock	⊕	⊕
Light-off reminder	Alarm	⊕	⊕
Power off reminder	Alarm	⊕	⊕
Door ajar reminder	Lamp	⊕	⊕
Driver's seatbelt reminder	Lamp and alarm	⊕	⊕
Passenger's seatbelt reminder	Lamp and alarm	⊕	⊕
Rear seatbelt reminder	Lamp and alarm	-	-
Low fuel warning	Lamp	⊕	⊕
Speed warning buzzer	Alarm	-	-

Transmission	5MT/6AT	6AT
Grade	GL	GLX

DRIVING AMENITIES

Electric windows	Driver side (up/down auto)	⊕	⊕
	Passenger side	⊕	⊕
	Rear	⊕	⊕
Central door locking		⊕	⊕
Keyless push start system		⊕	⊕
Keyless entry system		⊕	⊕
Air conditioner	Automatic	⊕	⊕
Heater		⊕	⊕
Rear A/C ventilation		⊕	⊕
Pollen filter	PM2.5 filter type	⊕	⊕
Audio	Sharkfin Antenna (mounted at rear of roof)	⊕	⊕
	Speaker x 4	⊕	⊕
	Centre speaker	-	⊕
	Tweeter x 2	⊕	⊕
	Subwoofer	-	⊕
	Infinity sound system	-	⊕
	10.1 inch Display Audio + Rearview camera	⊕	-
	10.1 inch Display Audio + 360°-view camera	-	⊕

Transmission	5MT/6AT	6AT
Grade	GL	GLX

INTERIOR

Cabin lights	Spot map lamp (Roof front) (Standard)	⊕	⊕
	Reading Lamp (Standard)	⊕	⊕
	Glove box light	⊕	⊕
Sun visors	Ambient lights (LED) with 64 multicolours	-	⊕
	Driver's side	⊕	⊕
	- with ticket holder	⊕	⊕
	- with vanity mirror	⊕	⊕
	- with illumination function	-	⊕
	Passenger's side	⊕	⊕
	- with ticket holder	⊕	⊕
Assist grips	- with vanity mirror	⊕	⊕
	- with illumination function	-	⊕
	Passenger's side	⊕	⊕
Cup holders	Rear x 2	⊕	⊕
	Front x 2	⊕	⊕
Bottle holders	Rear armrest x 2	⊕	⊕
	Front x 2, Rear x 2	⊕	⊕
Centre console box with armrest		⊕	⊕
Head-Up Display		-	⊕
Shift knob	Black	⊕ (MT)	-
	Black with satin chrome accent	⊕ (AT)	⊕ (AT)
Wireless charger	Front	⊕	⊕
12V accessory socket	Front, Luggage area	⊕	⊕
USB charger	Front (Type C+C)	⊕	⊕
USB charger	Rear (Type C+C)	⊕	⊕
Foot rest	Driver's side	⊕	⊕
Inside door handles	Chrome	⊕	⊕

Transmission	5MT/6AT	6AT
Grade	GL	GLX

SEATS

Seat upholstery material	Synthetic leather	-	⊕
Front seats	Seat height adjuster (driver's side)	⊕	⊕
	Seat height adjuster (passenger's side)	-	-
Rear seats	Seatback pocket (driver's side)	⊕	⊕
	Seatback pocket (passenger's side)	⊕	⊕
	60:40-split single-fold	⊕	⊕
8-way power adjustable driver's seat	Head restraint x 3 (separate type)	⊕	⊕
Ventilated front seats		-	⊕

LUGGAGE AREA

Luggage shelf		⊕	⊕
Luggage area light		⊕	⊕

Transmission	5MT/6AT	6AT
Grade	GL	GLX

⚙ : Standard - : Not available

**Bluetooth is a registered trademark of Bluetooth SIG, inc.

***ESP is a registered trademark of Daimler AG.

ESP is designed to help keep the Across under control. However, its effectiveness depends on driving conditions and the state of the road surface.

SAFETY, SECURITY, AND ENVIRONMENTAL COMPATIBILITY

Electric Parking Brake (EPB)		⚙ (AT)	⚙ (AT)
SRS front dual airbags		⚙	⚙
SRS side airbags		⚙	⚙
SRS curtain airbags		⚙	⚙
Seatbelts	Front: 3-point ELR seatbelts with pre-tensioner and force limiter	⚙	⚙
	Rear: 3-point ELR seatbelts x3	⚙	⚙
ABS with EBD function		⚙	⚙
ESP ^{***}		⚙	⚙
DSBS II (Dual Sensor Brake Support II)		-	⚙
AEB (Autonomous Emergency Brake)	Front only	-	⚙
LDW (Lane Departure Warning)		-	⚙
LKA (Lane Keep Assist)		-	⚙
High beam assist		-	⚙
RCTA (Rear Crossing Traffic Alert)		-	⚙
Weaving alert		-	⚙
BSM (Blind Spot Monitor)		-	⚙
LDP (Lane Departure Prevention)		-	⚙
ACC (Adaptive Cruise Control)		-	⚙
Hill-hold control		⚙	⚙
Parking sensors	Front	-	⚙
	Rear	⚙	⚙
LED-DRL (Daytime Running Lights)		⚙	⚙
High-mount stop lamp		⚙	⚙
Immobiliser		⚙	⚙
Security alarm		⚙	⚙

YOUR WORLDS. YOUR COLOUR CHOICES.

The Suzuki Across is available in a range of refined colours, designed to move seamlessly between every world you explore.



215/60 R17 + alloy wheels (Painted) (GL)

215/60 R17 + alloy wheels (Machined) (GLX)



SUZUKI

COMPLETE

Suzuki understands that purchasing a new vehicle is a substantial investment. Our unwavering commitment to customer satisfaction is represented in our 'Suzuki Complete' package, which includes every aspect of after-sales support, with warranty, service plan and roadside assistance standard.

Warranty

All Suzuki models are covered by a comprehensive promotional warranty against any defects for a period of 5 year/200 000km. This is supported by a six-year body corrosion warranty subject to terms and conditions.

Service Plan

The Across benefits from a 4-year/60 000km service plan. This plan includes the replacement of oil, the oil filter, fuel filter, brake fluid, air filter and accessory belts, but excludes tyres, brakes and other wear-and-tear items.

Service Intervals

15 000km or one year, whichever comes first.

Roadside Assistance

Every new Across comes with a five-year roadside assistance plan. Some of the benefits offered by this comprehensive package include: battery and locksmith call-out services, mechanical and electrical, breakdown towing (accident towing is optional), emergency medical rescue, vehicle repatriation and a stand-by-you roadside security armed-response service.

THE SUV THAT FITS REAL LIFE

The Suzuki Across isn't about choosing one version of yourself. It's about moving comfortably between all of them, with confidence, style, intelligence and ease.

From refined design and spacious comfort to advanced connectivity, efficient mild-hybrid performance and a wide suite of safety technologies, the Suzuki Across is built for the full shape of modern life.



READY TO MOVE?

ACROSS

MOVE BETWEEN WORLDS

All care is taken to ensure the accuracy of this brochure at the time of print approval. Specifications, features, prices and model availability may vary from those specified and may change without notice. Always consult your authorised Suzuki Dealer or refer to www.SuzukiAuto.co.za for the latest details on all models. SUZUKI AUTO South Africa (PTY) Ltd will not be held liable for any loss as a result of reliance on the content of this brochure, whether in negligence or otherwise. Vehicles are shown for illustrative purposes only and may not depict exact specifications. Published April 2026.



SUZUKI AUTO SOUTH AFRICA (PTY) LTD | Tel: 0861 511 111
No.52 Saturn Crescent, Linbro Business Park, Frankenwald, Marlboro, Sandton
www.SuzukiAuto.co.za

